



M-TRON TRANSFORMING VEHICLE

PROTOTYPE (1987)

INSTRUCTIONS

CONCEPT BY LEGO

PHOTOGRAPHY & INSTRUCTIONS

BY COSMIC.BRICK



Introduction

This M-Tron Transforming Vehicle is a prototype from 1987, as depicted in the awe inspiring interview with Jens Nygaard Knudsen by Mark Stafford, in BrickJournal issue 6, vol. 2 released in 2009.

This thing that should not be is another "Magna-Tron" prototype from 1987, now known as M-Tron. It's a rover transforming into a mecha. It levels up in size using an impressive transformation. My younger self would have loved a rover this size. And finally trans-neon green! Except for the canopy. Ugh.

To reverse engineer this was quite hardcore. The revelation was to flip one end of a 2x8 hinge plate (aligning all studs to the top side) for the vehicle's base. See the first few building steps on how to achieve this. After that, you need to stack a lot of plates (2 wide) for the mechanism to work smoothly. I cancelled a few other building methods because the proportions didn't look accurate. What's left for the viewers imagination is what happens in the middle of the lower back side. I kept it simple, using authentic parts. Upon finishing, I expected the model to consist of more parts.

On the end of the flipped hinge plate I've added an arrow decorated tile (as with many Classic Space builds, an arrowed tile always hinted play features). Pushing it makes the vehicle stand upright. Pressing on its back straightens it back out into a neat rover. All too easy and quite clever. I've added three extra pages showing the operation.

The model uses curved slopes (first seen in sets in 1992). Like the Forklift-Mecha (instructions issued separately), this also uses a M-Tron decorated tile and some off-beat yellow, see those lever bases. The medium hard plastic wheels, together with the computer decorated tile were first used in sets from 1990. Canopy first seen in Town sets in 1992. Feel free to replace it though (see page 5, lower right), as a trans-neon green windscreen reached production in 1998 (Insectoids, Extreme Team).

Besides the small cabin this prototype is an absolute favourite. Wishing you the same amount of joy by sharing these detailed steps. Let's go!

Have fun building!
Chris (cosmic.brick)



Excerpt from "The Truth About Space!"

Rover comparison

Photo from Niels Milan Pedersen's personal LEGO archives, as published in BrickJournal issue 6, volume 2 (2009).



Replica model by @cosmic.brick.



Mecha comparison

Photo from Niels Milan Pedersen's personal LEGO archives, as published in BrickJournal issue 6, volume 2 (2009).



Replica model by @cosmic.brick.



The model

Replica model by @cosmic.brick.

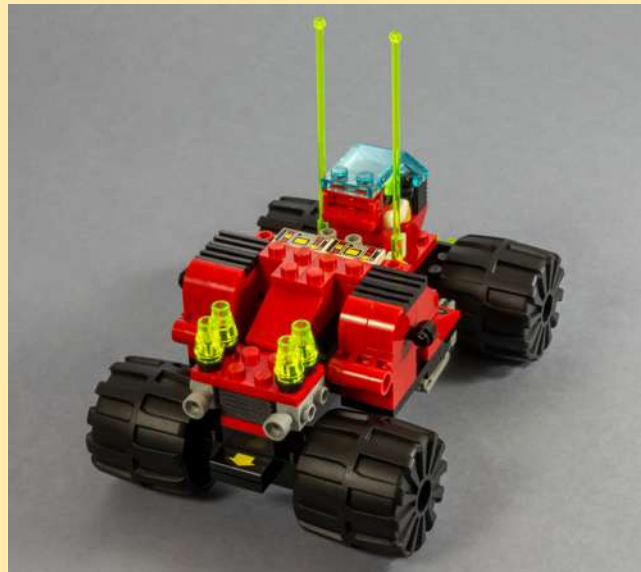

Get your parts ready!

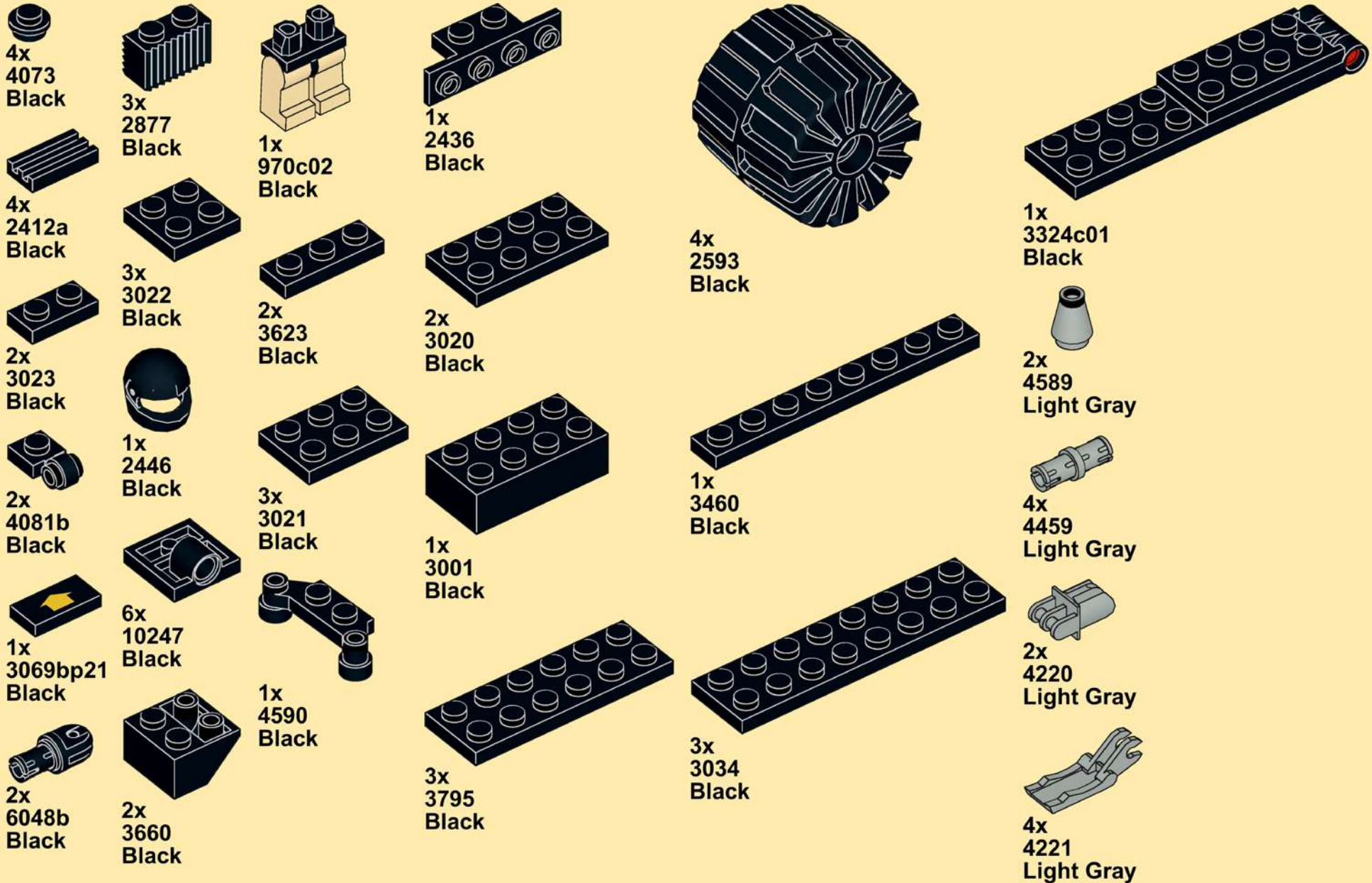



2x
4595
Light Gray



2x
2412a
Red



4x
6091
Red



2x
4275b
Red

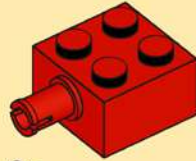

2x
4730
Red

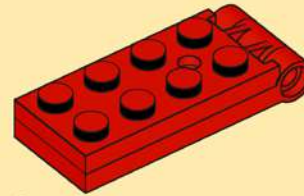

2x
3149c01
Red



4x
4589
Trans-Neon Green



2x
3069bp68
White



1x
3938
Red

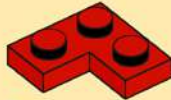

2x
2420
Red

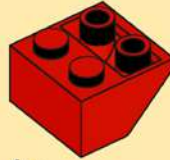

1x
3660
Red



2x
3298p68
Red

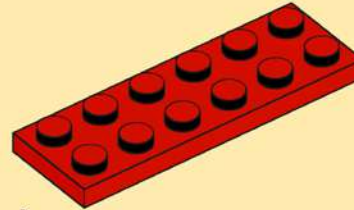

1x
3795
Red



1x
2447
Trans-Neon Green

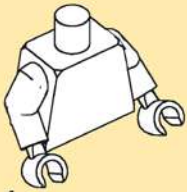

1x
973c00
White

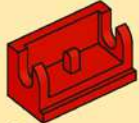

1x
3937
Red



1x
3022
Red

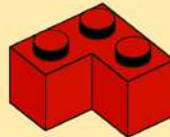

2x
2357
Red

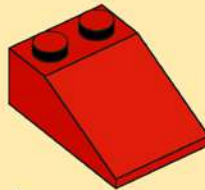

1x
3298
Red



1x
3626ap01
Yellow

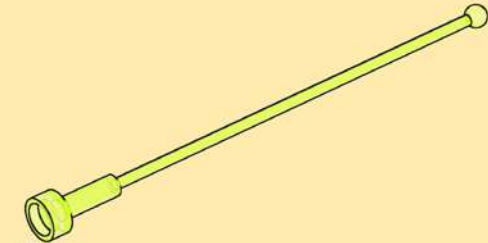

2x
2569
Trans-Neon Green



2x
3024
Red



2x
3040
Red



1x
3068bp68
Red



1x
4864a
Red

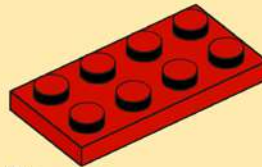

2x
3020
Red



2x
4592c02
Yellow

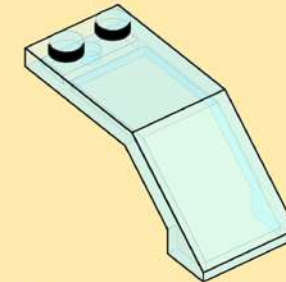

1x
6070
Trans-Light Blue



3x
3023
Red

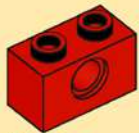

2x
3700
Red

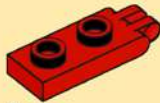

2x
4276b
Red



4x
4073
Trans-Neon Green

1

What's going on here?

The building steps show how to build an exact replica of the original model. Every M-Tron prototype depicted in the article uses minifigs without air tanks. I totally understand if you still want to add them, but in this case the minifigure only fits inside the driver cabin without air tanks.

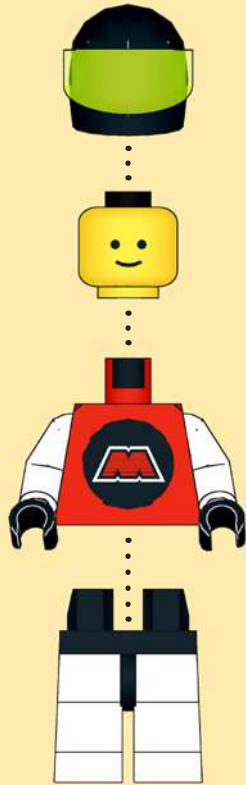

2

Hack the hinge!

Although they consist of three parts, (just like torso's) LEGO supplies these hinge plates pre-assembled. For the vehicle's base, the top plate needs to be flipped over – aligning all studs to the top side when opened.

To continue, the red pivot needs to be removed. Use a technic axle or something similar to push it out.

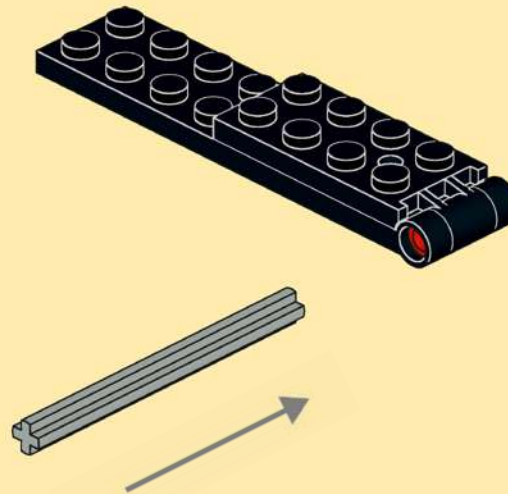

3

If you don't have a technic axle at hand, you can also use a classic antenna. For stability it helps to keep the two plates connected.

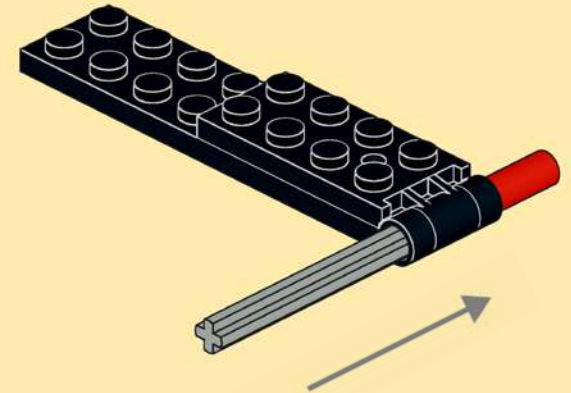

4

The red pivot doesn't need to be pushed out completely to remove the top 2x4 hinge plate.

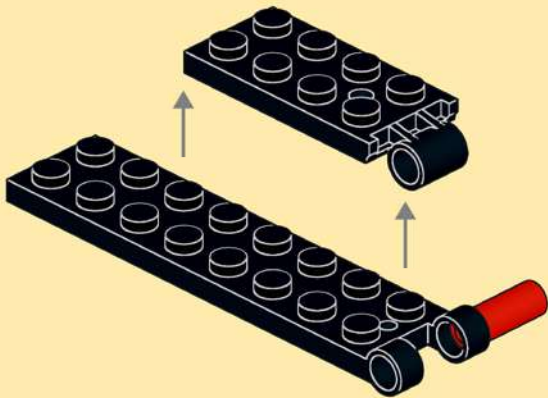

5

Put the 2x4 plate back in place, but with all studs aligned to the top side when fully opened.

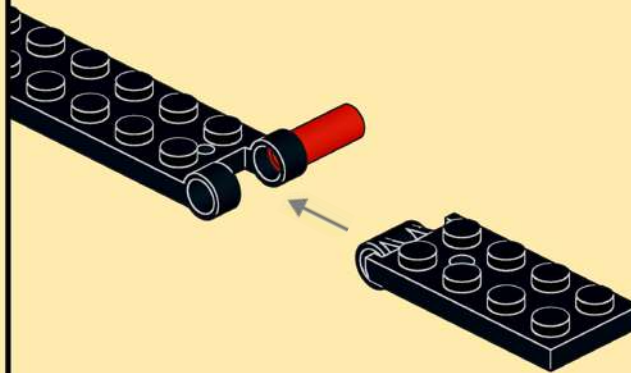

6

Ready? Great! Push the pivot back in, and start building!

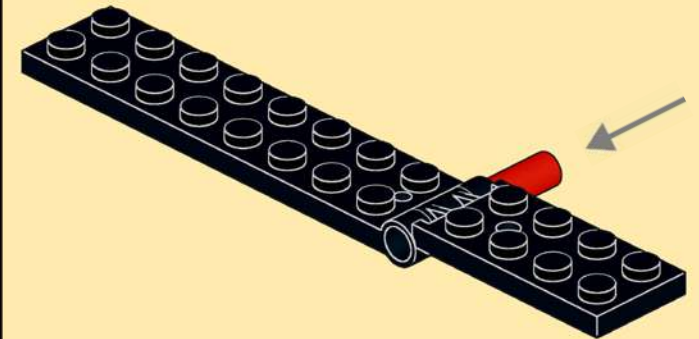

7

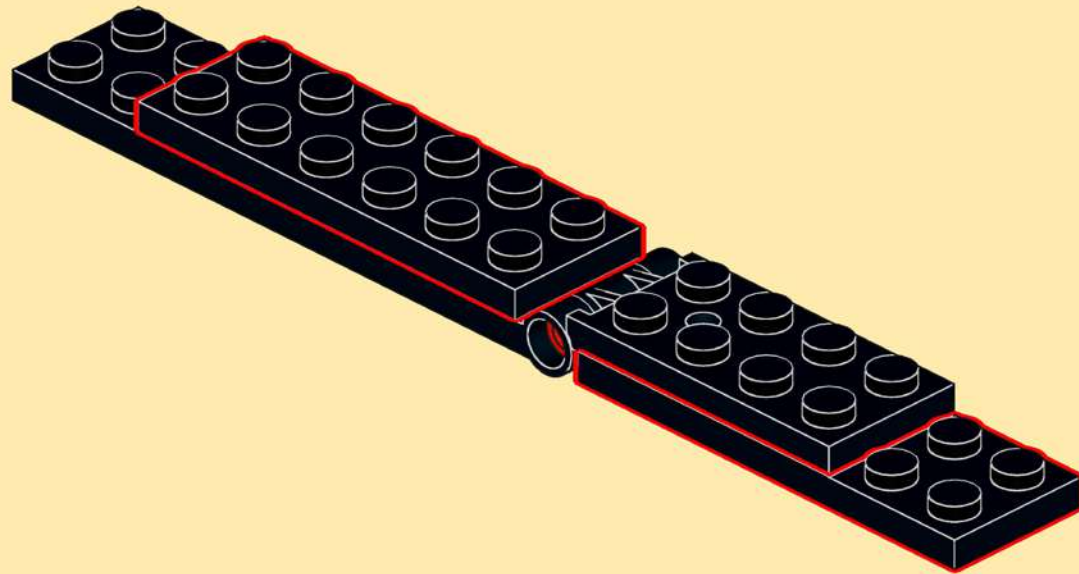

8

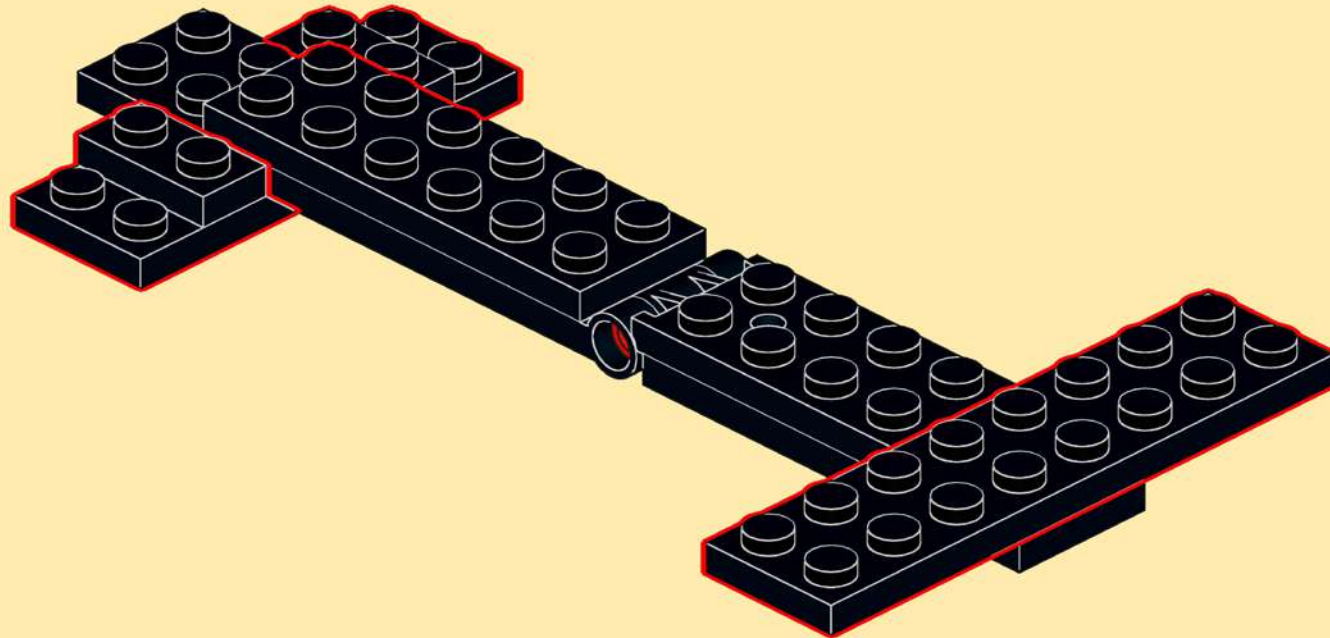
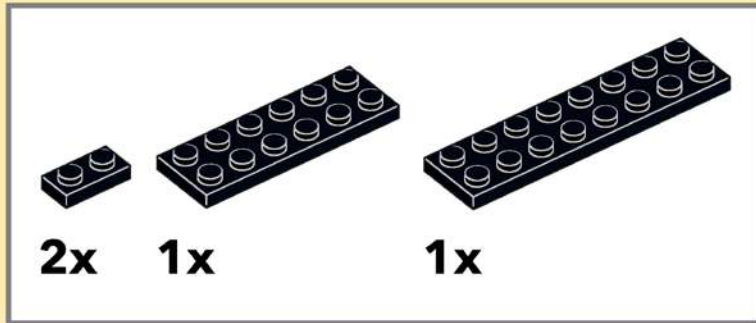

9

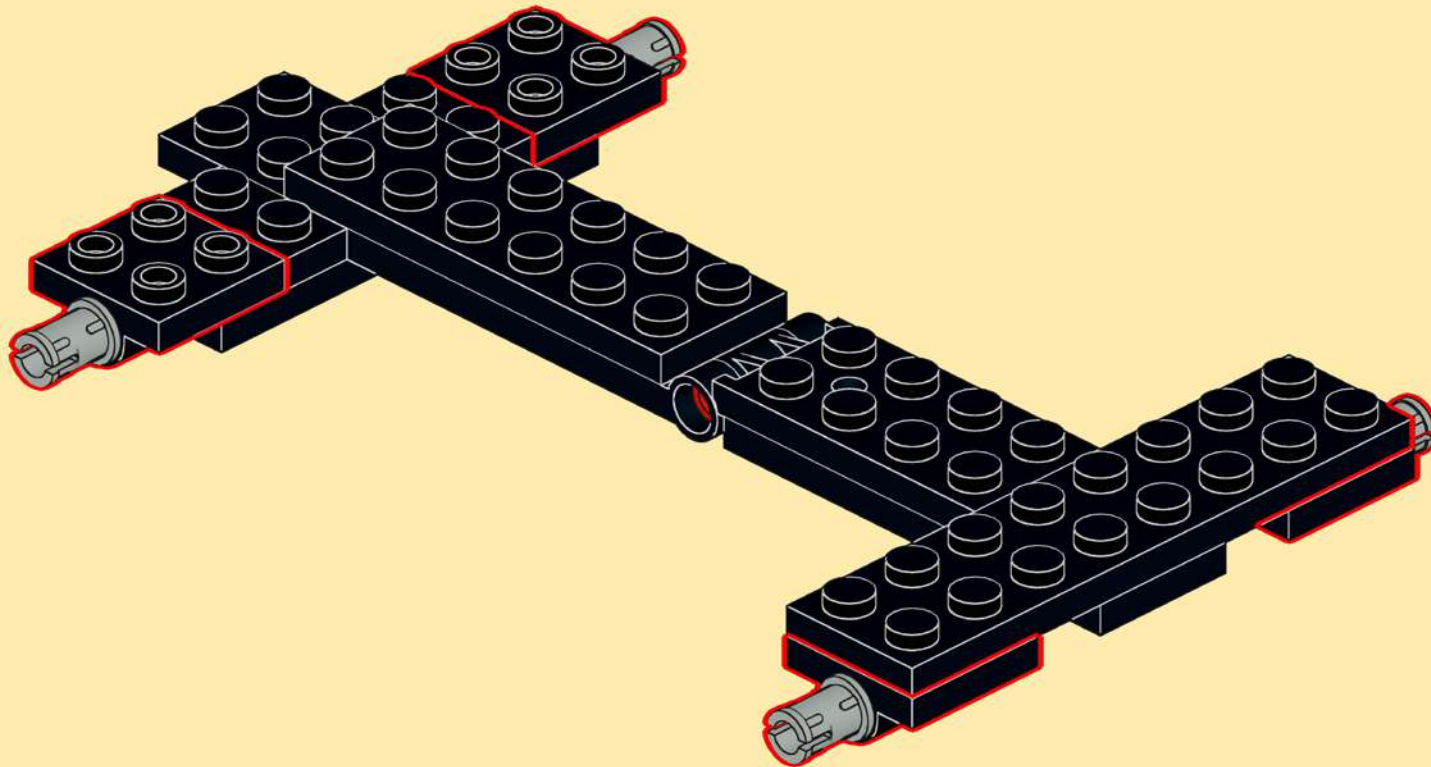
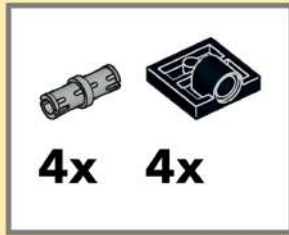

10

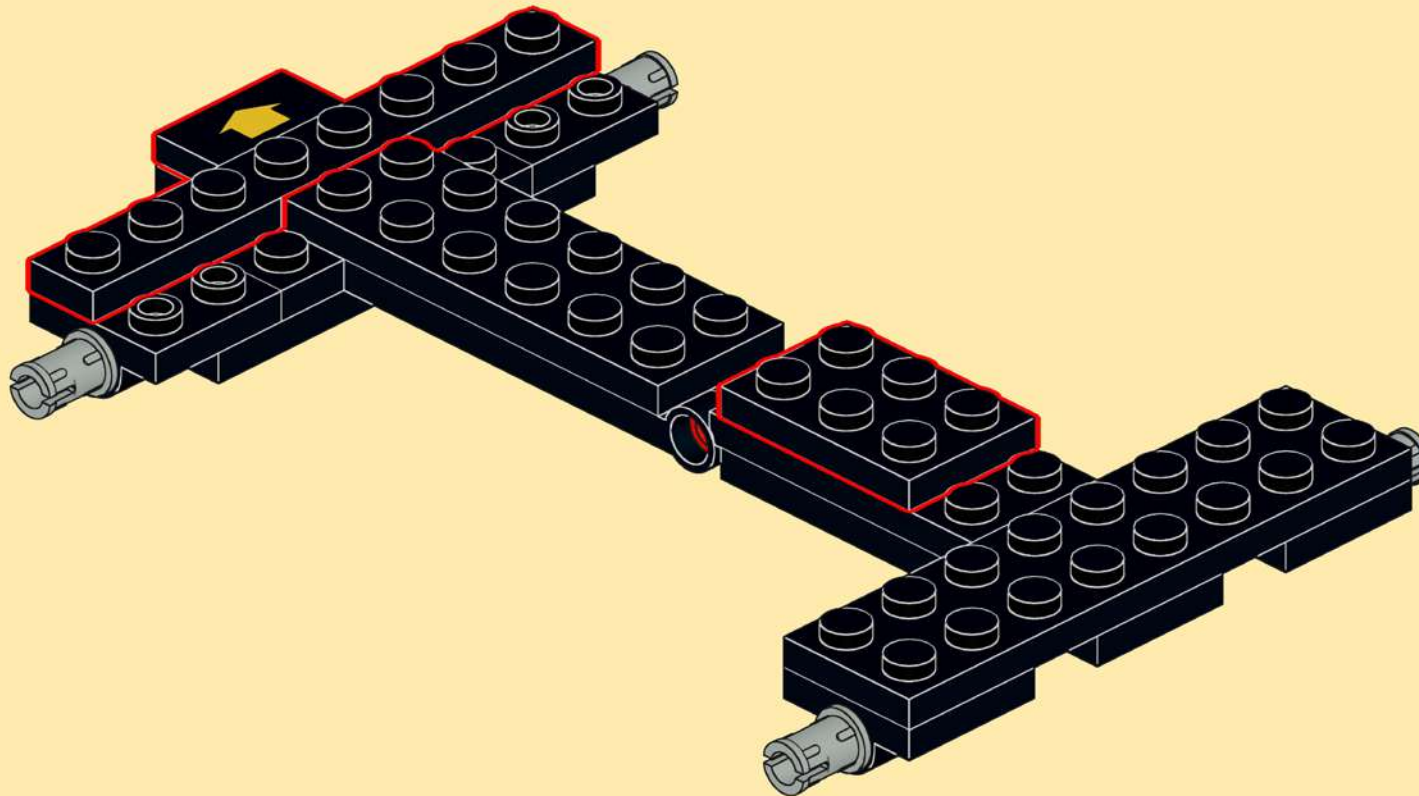
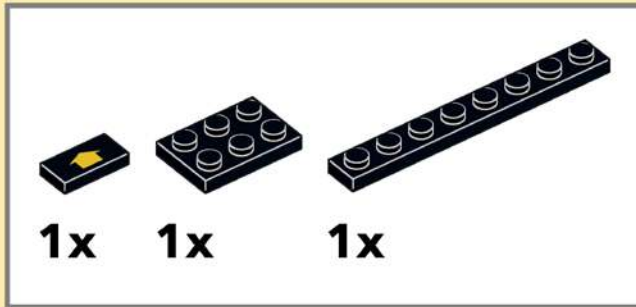

11

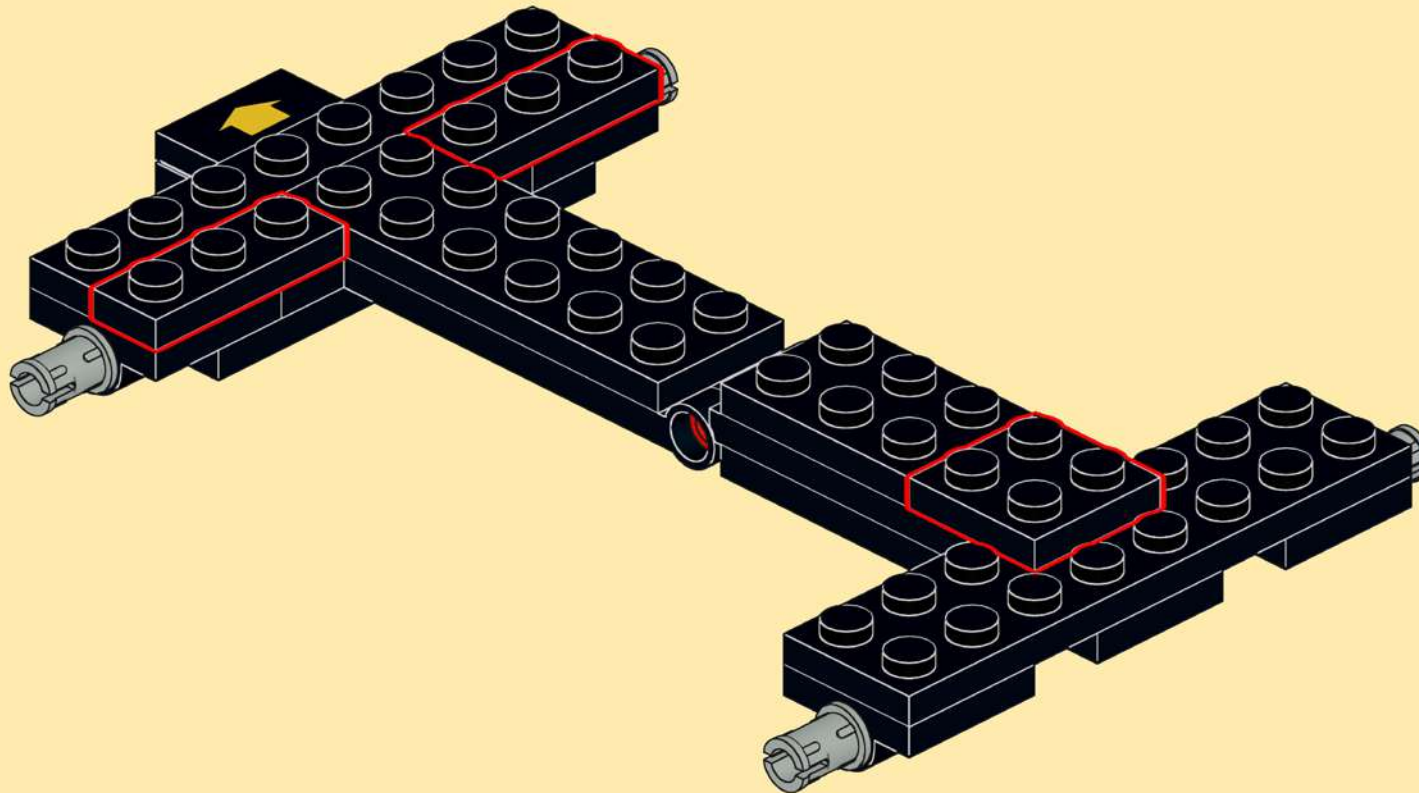
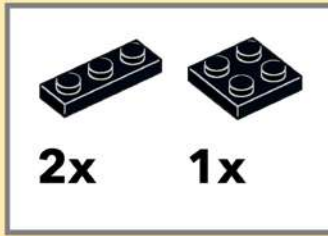

12

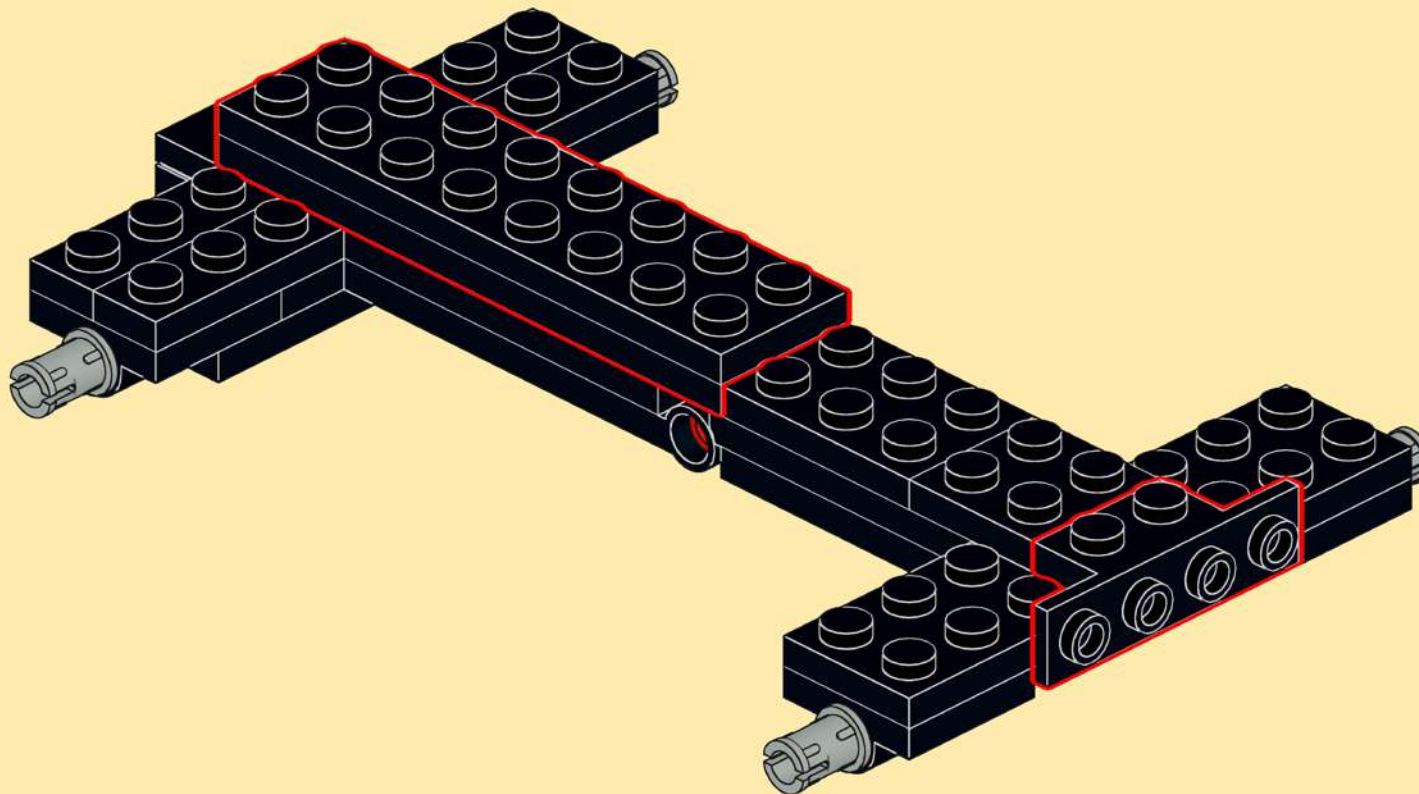
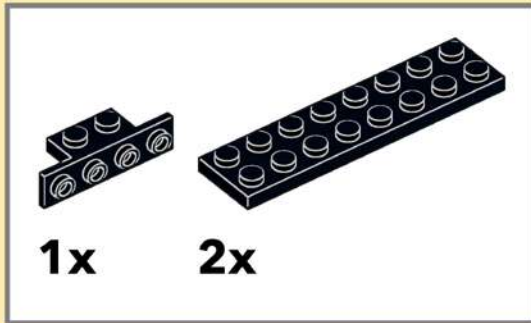

13

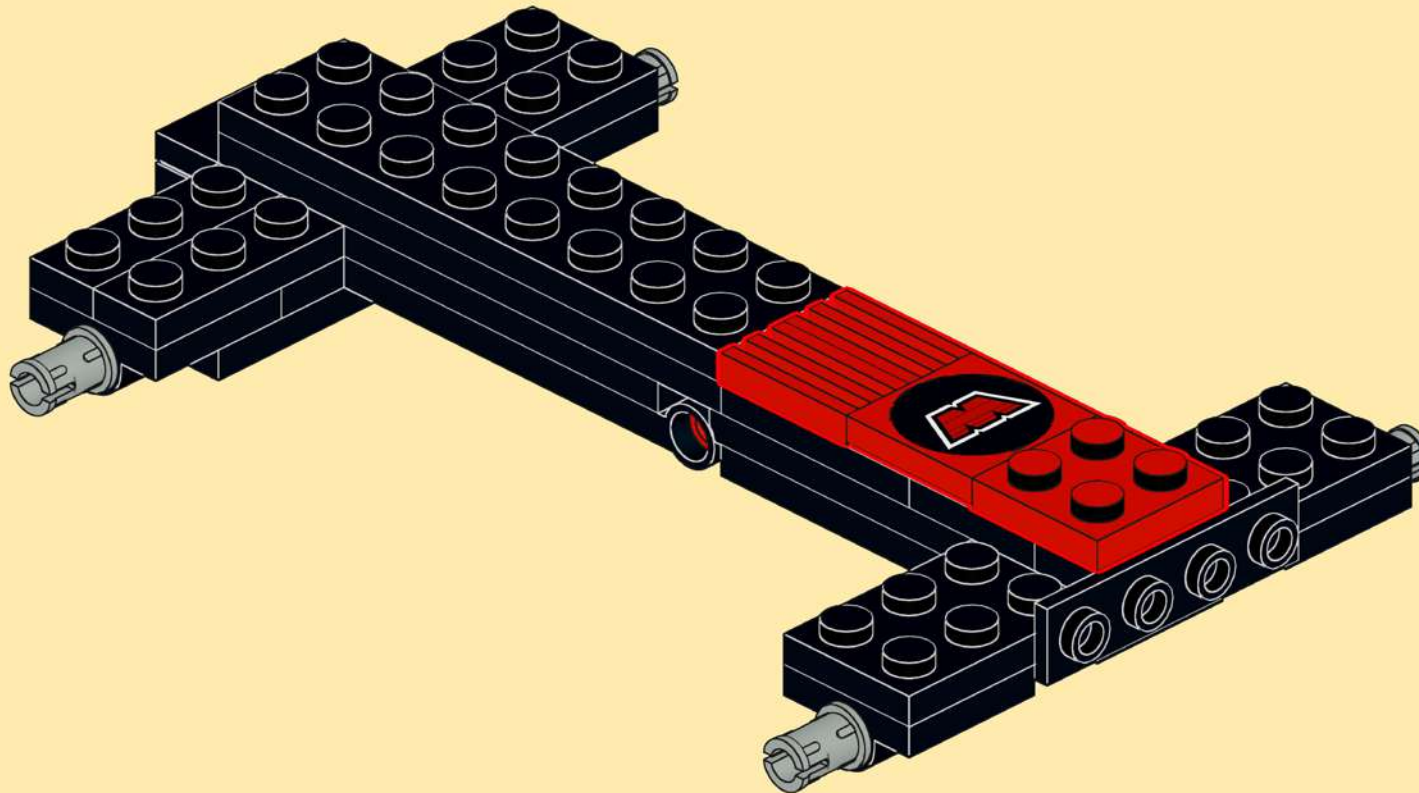
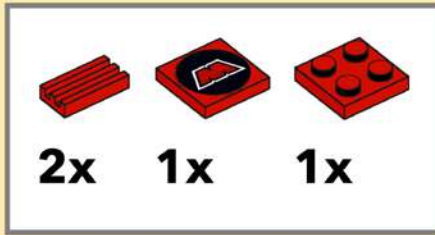

14

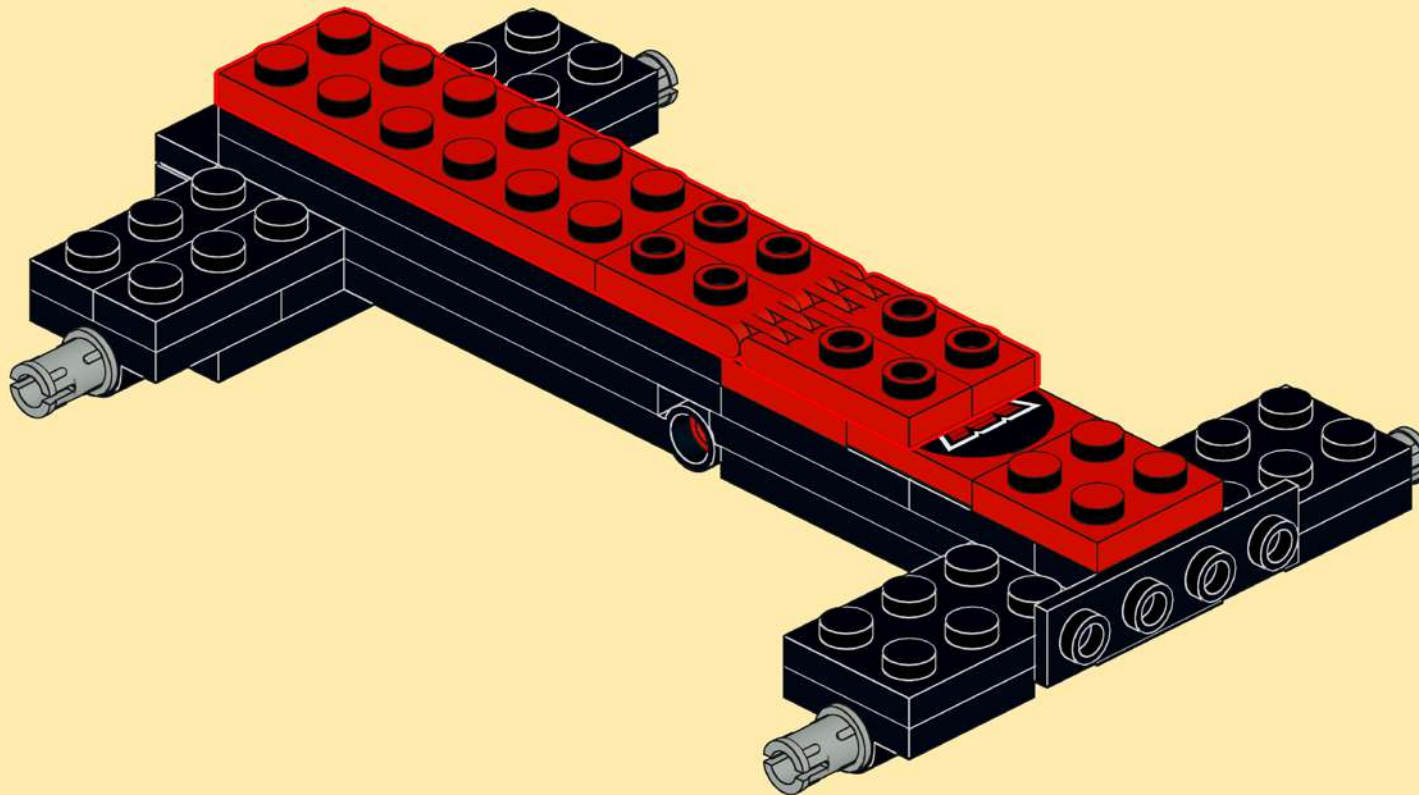
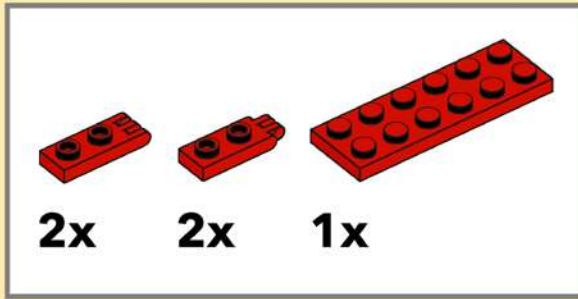

15

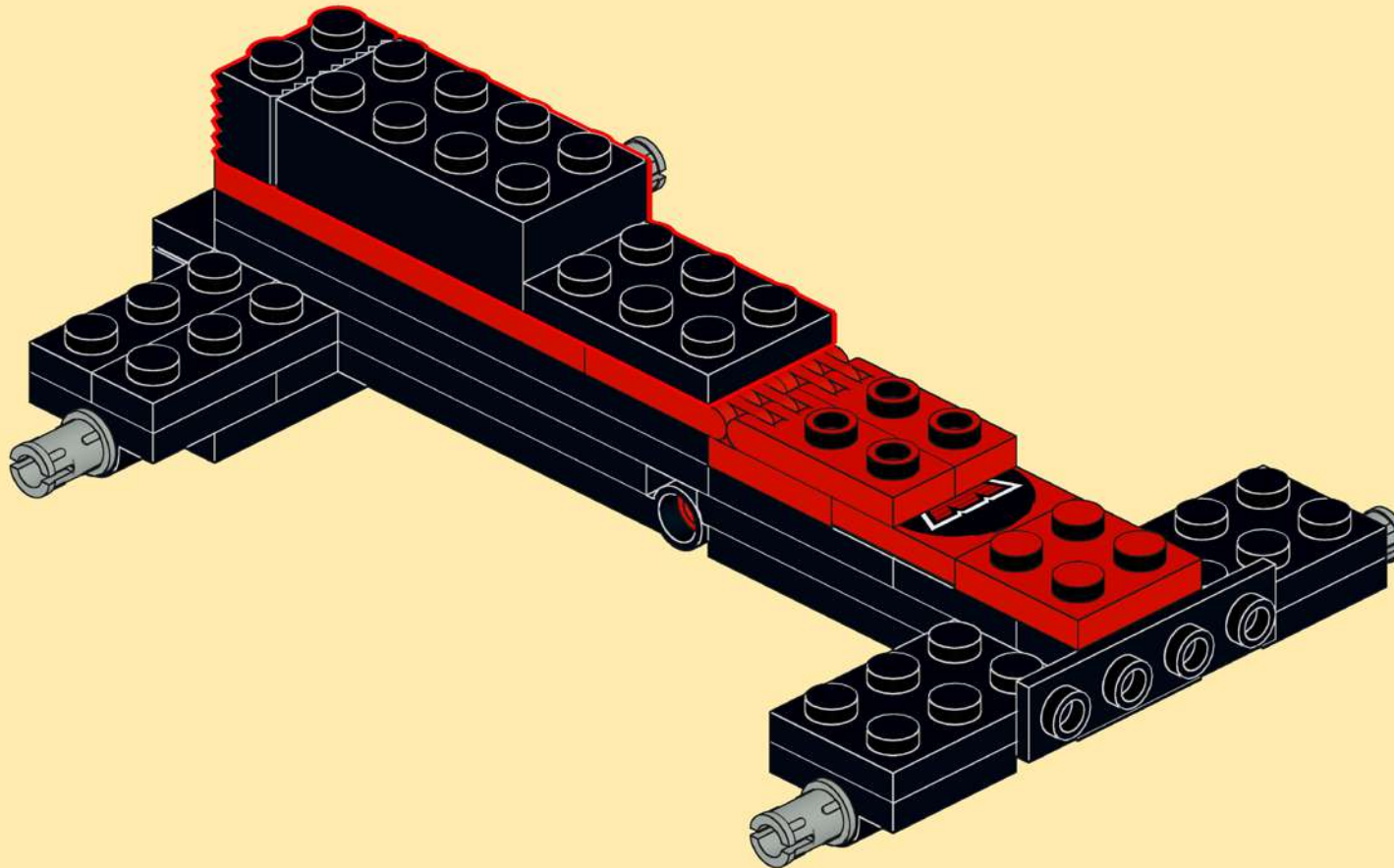
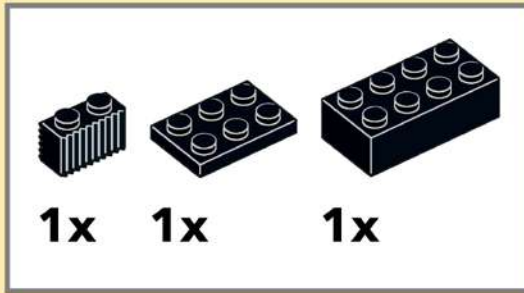

16

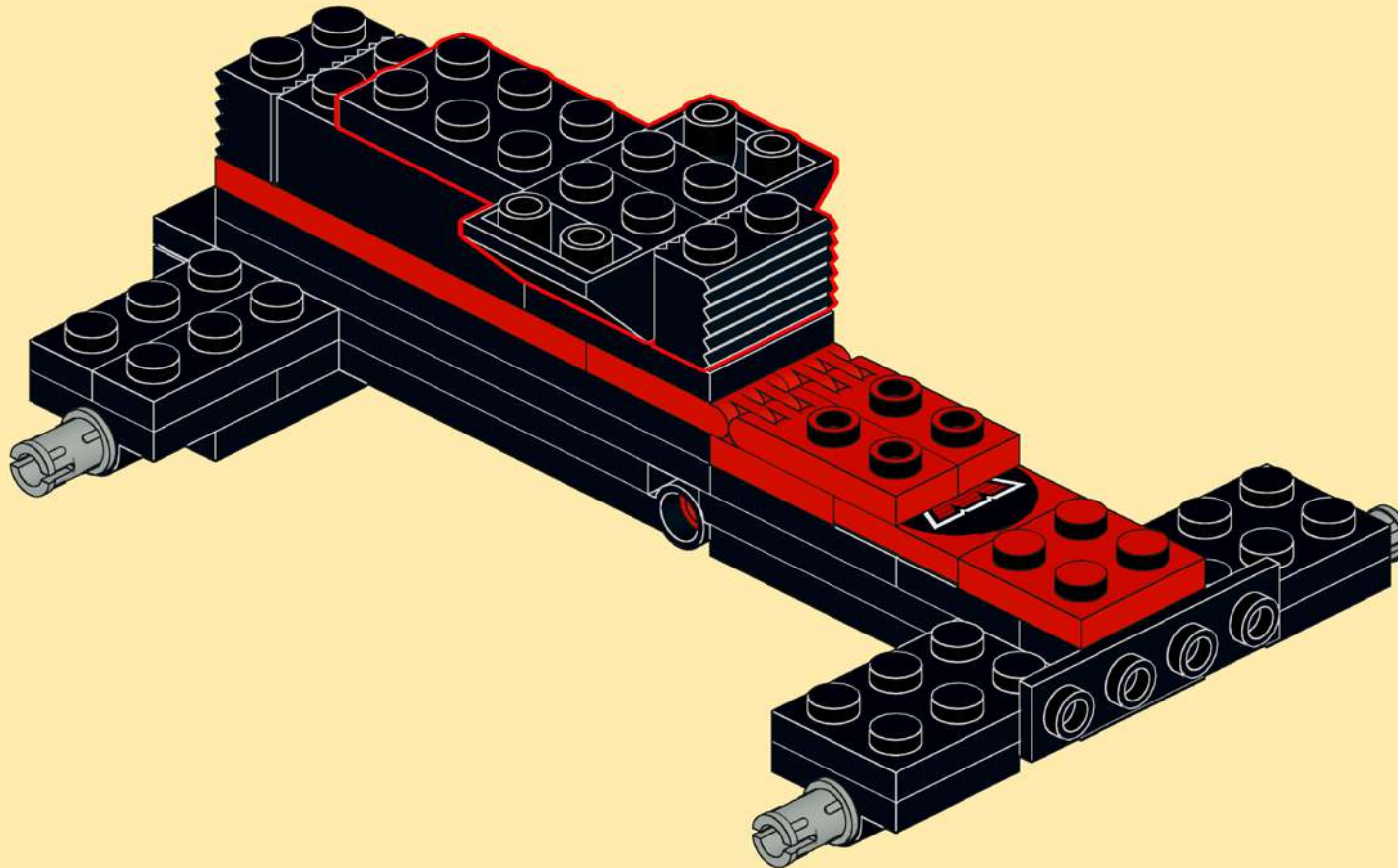
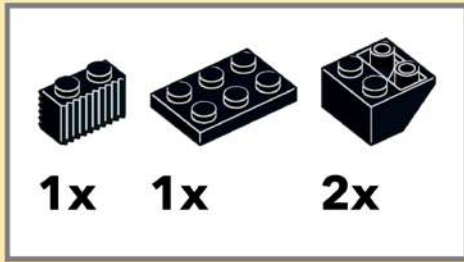

17

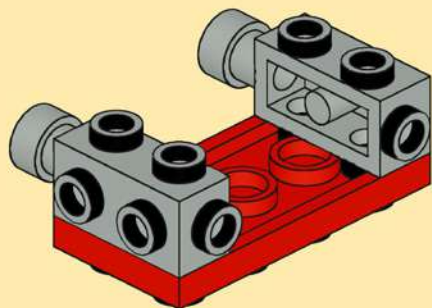
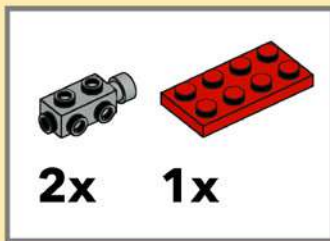

18

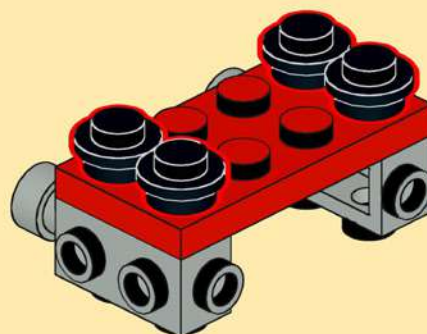

19

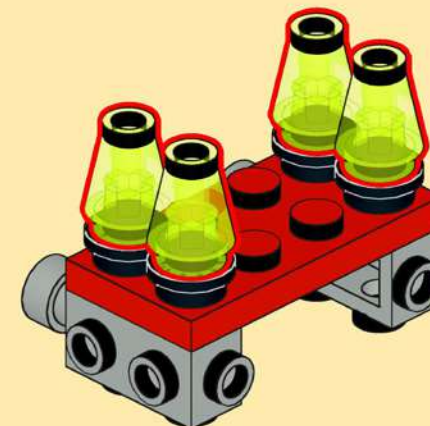

20

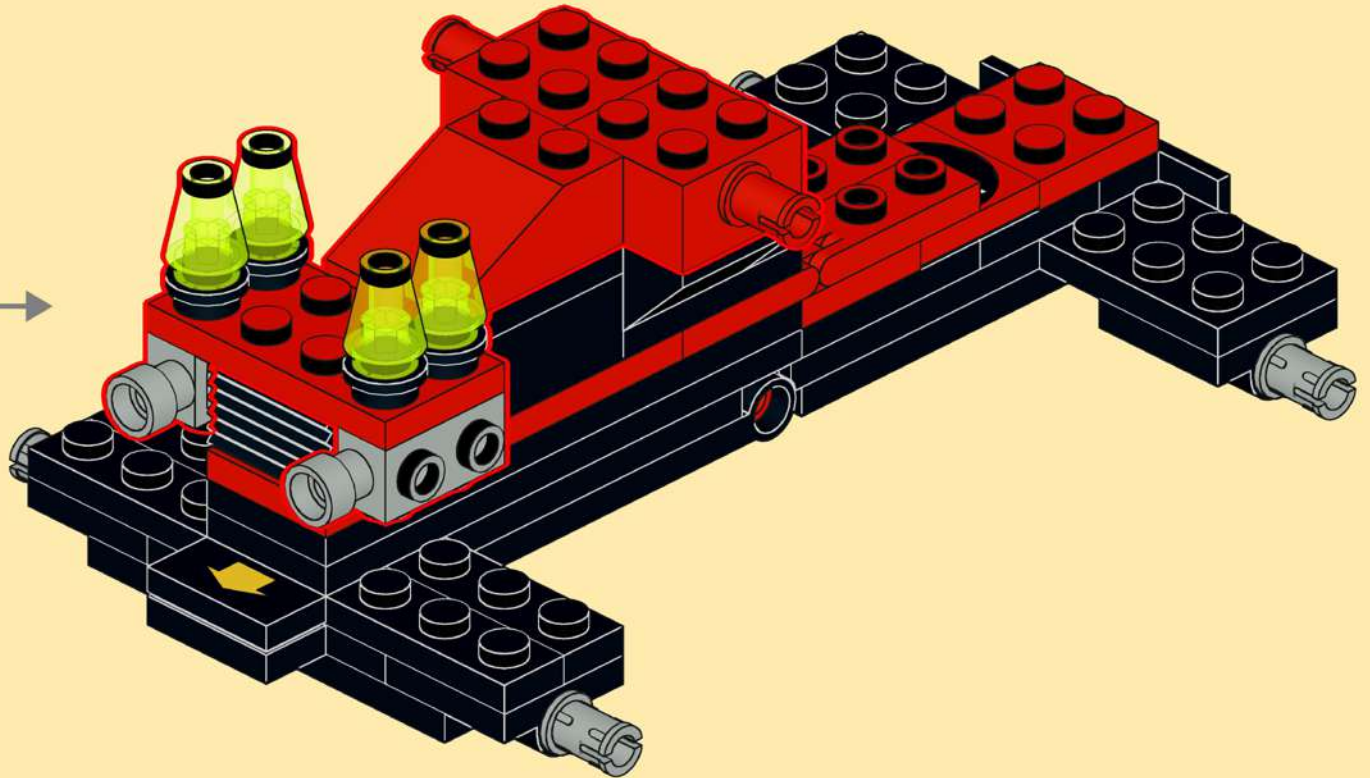
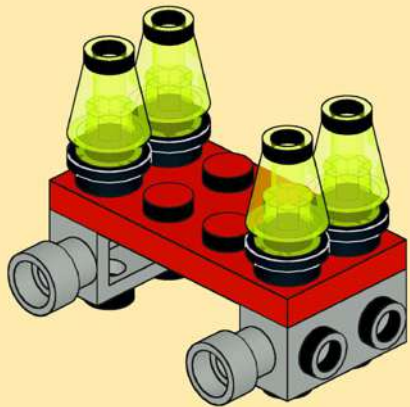
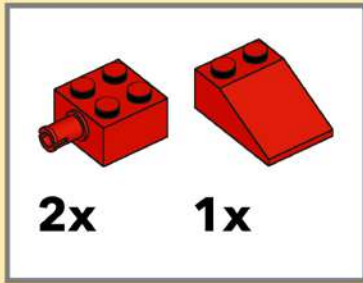

21

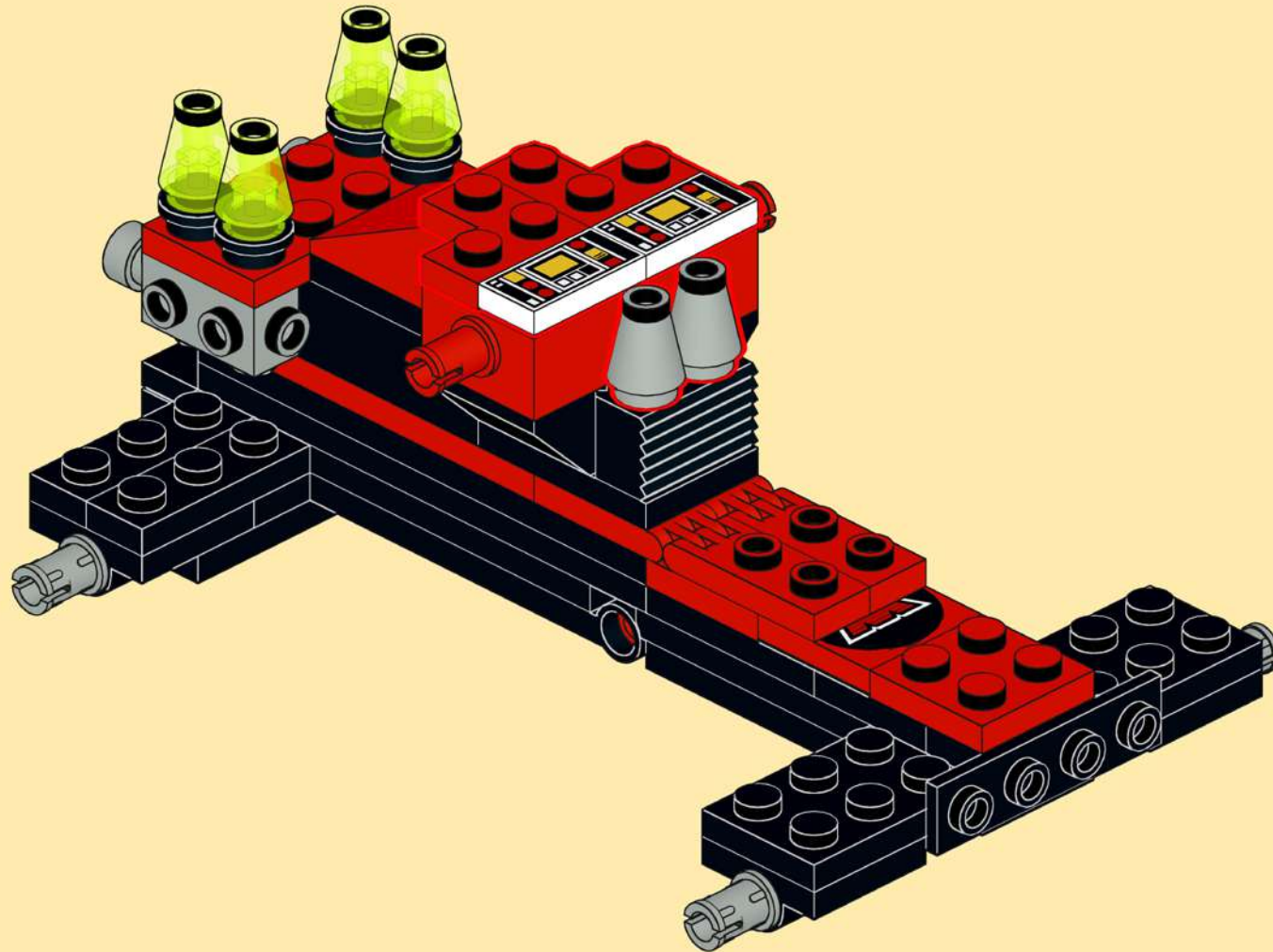
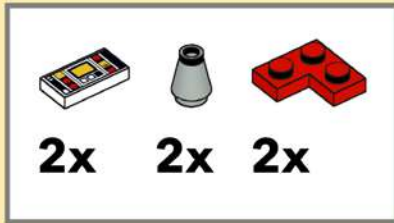

22

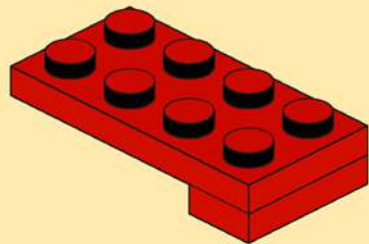
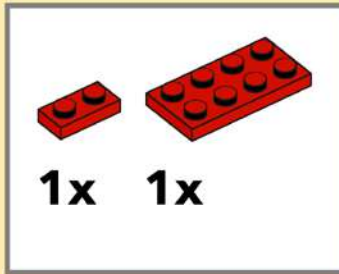

23

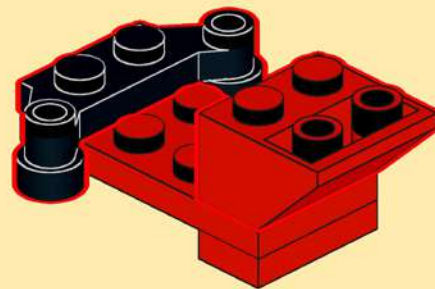
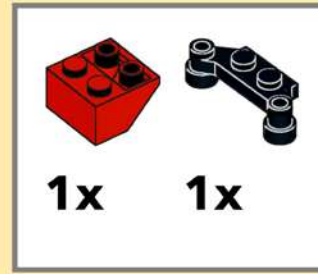

24

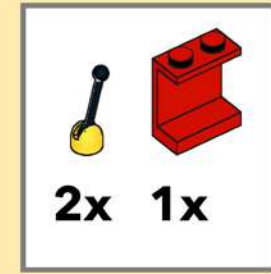

25

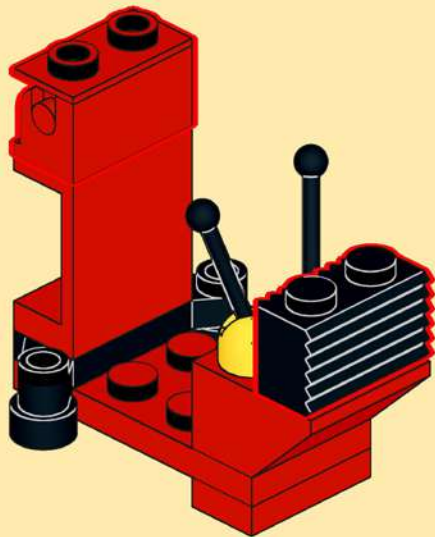
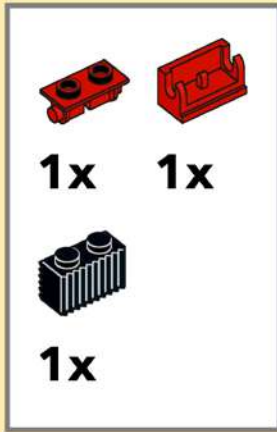

26



A tight squeeze –
The minifigure only fits
inside without air tanks.



27

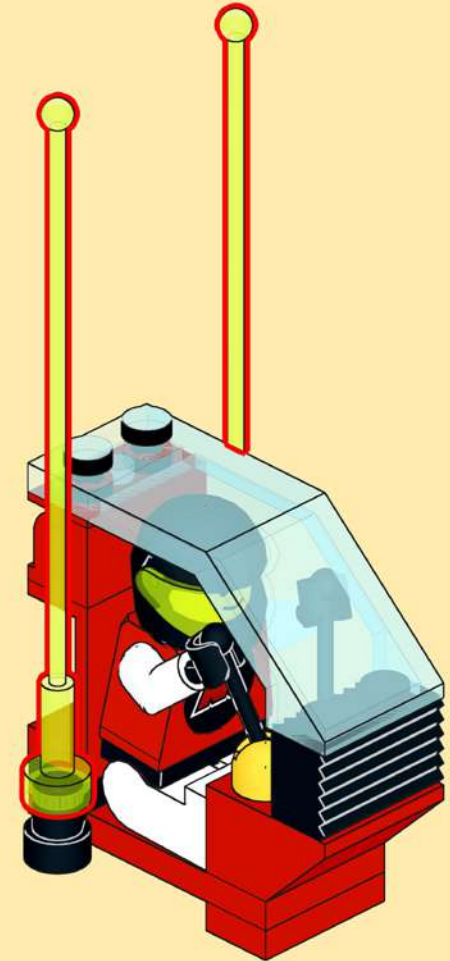
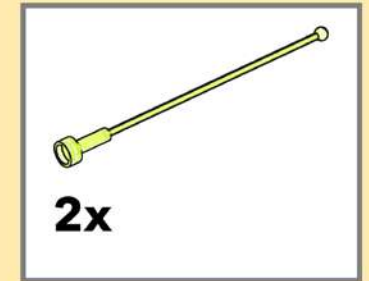

28

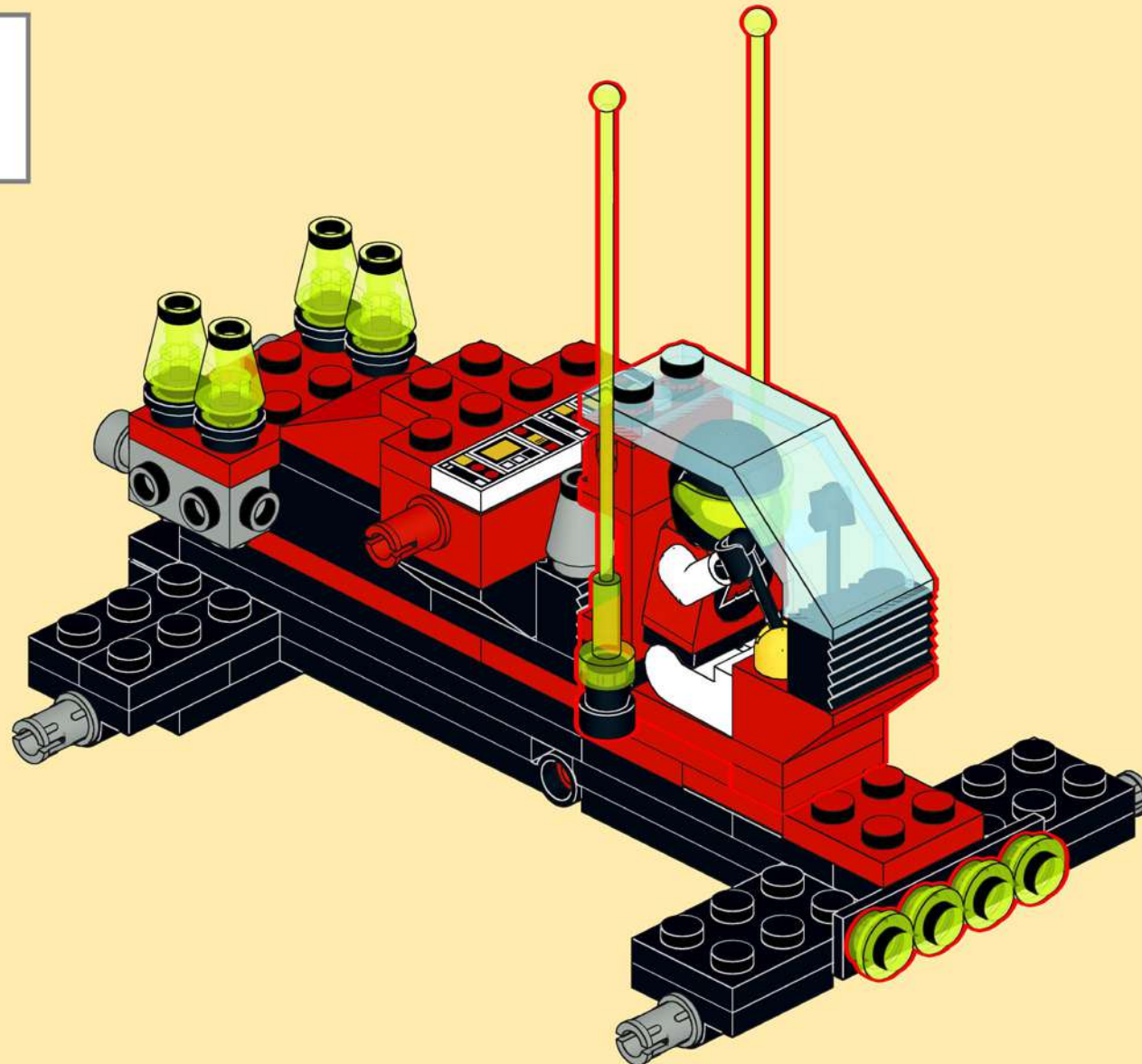

29

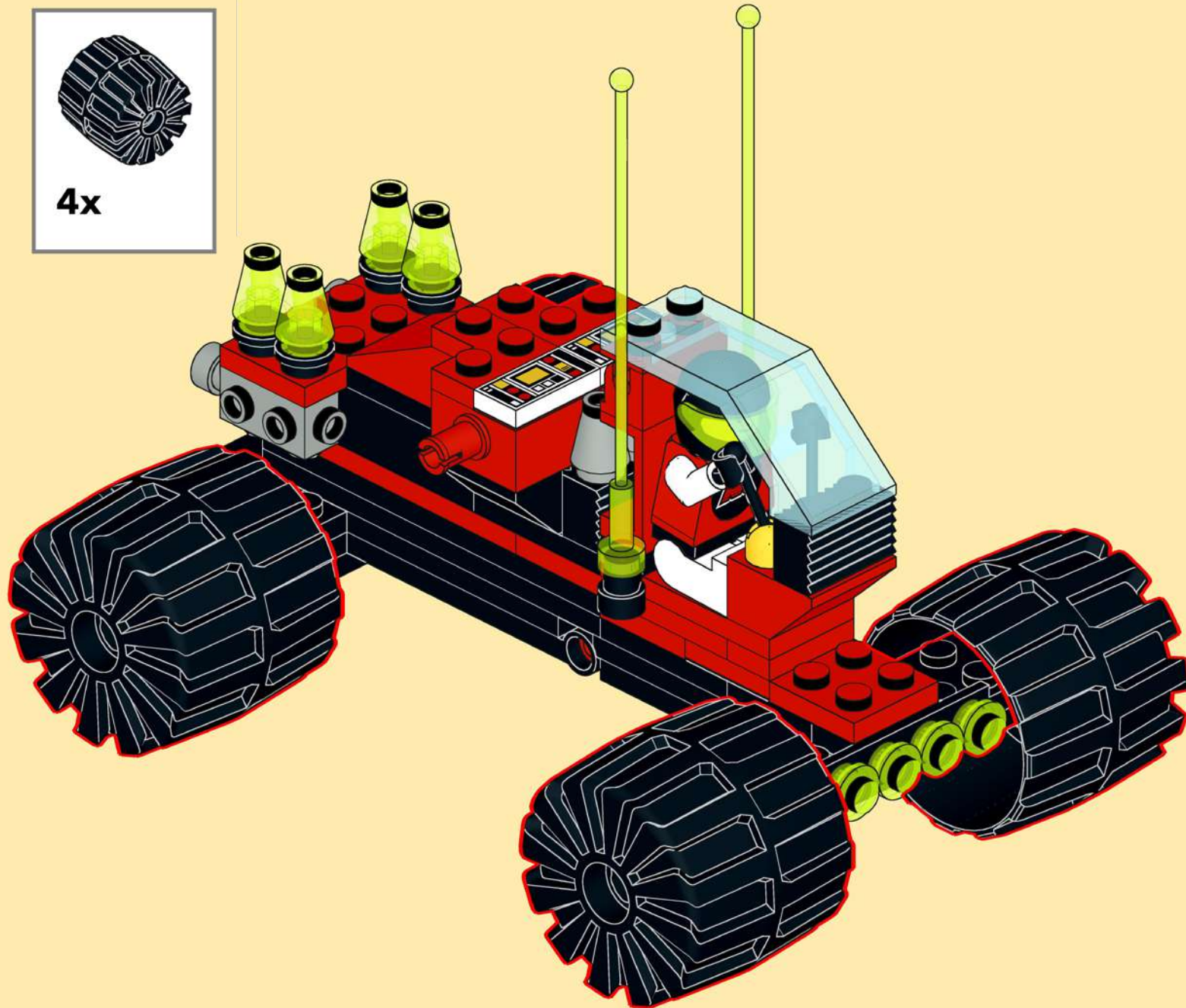

30

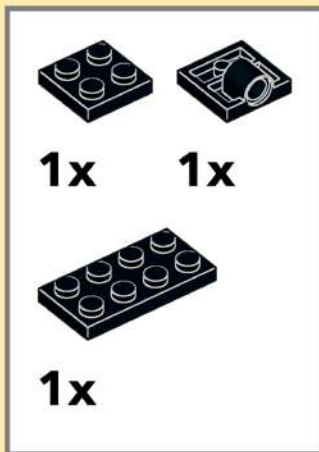

31

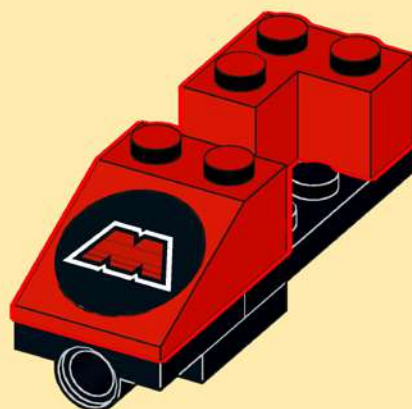
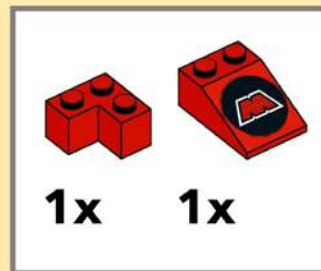

32

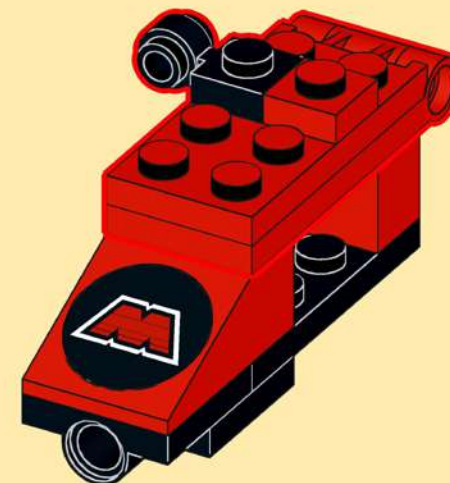
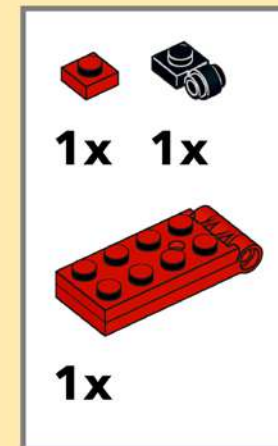

33

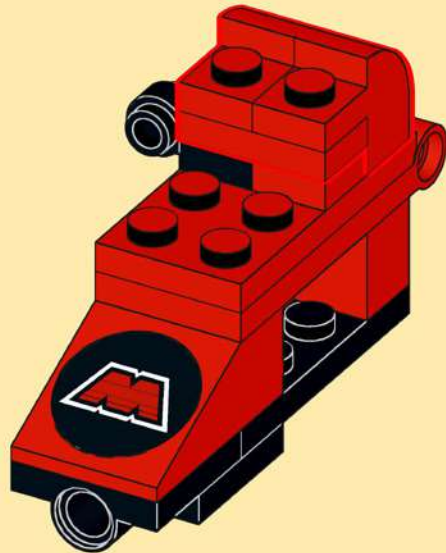
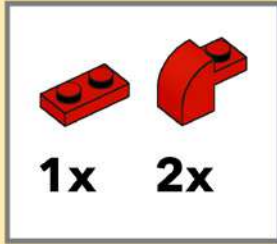

34

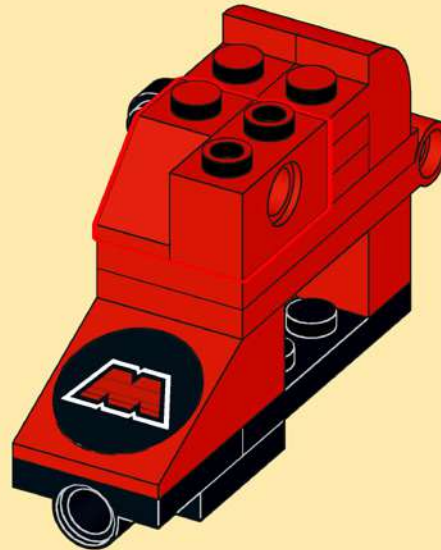
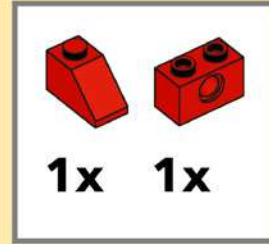

35

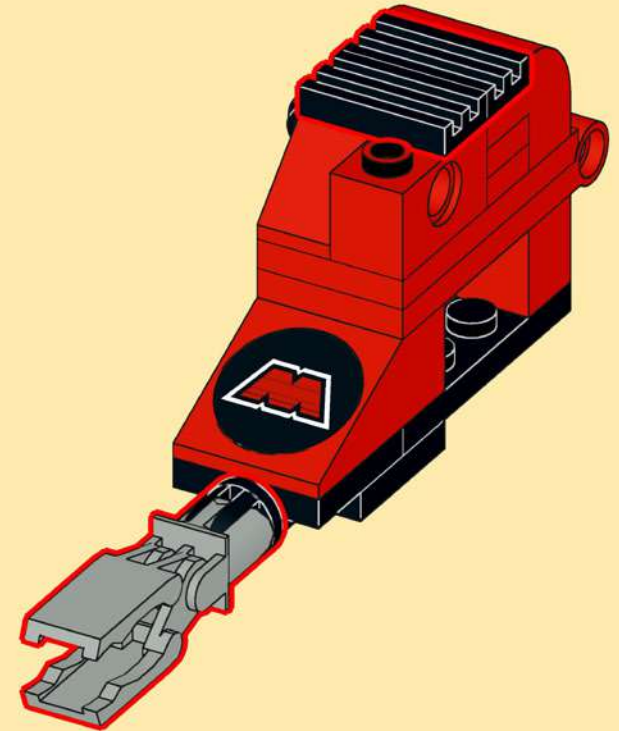
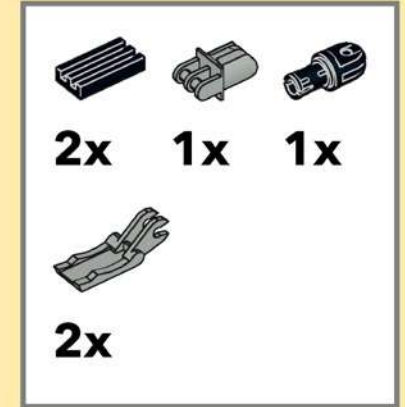

36

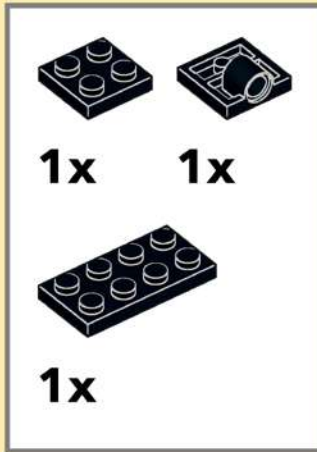

37

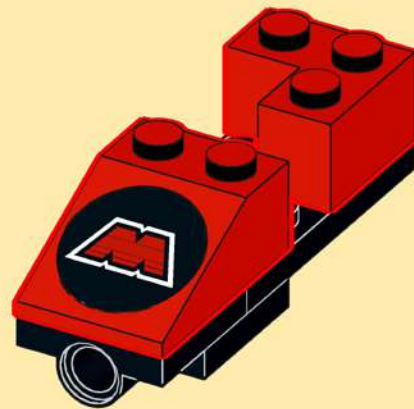
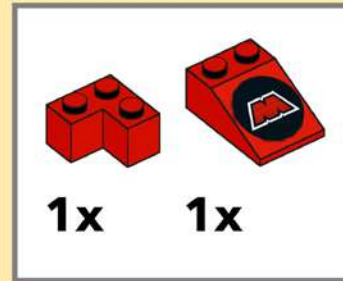

38

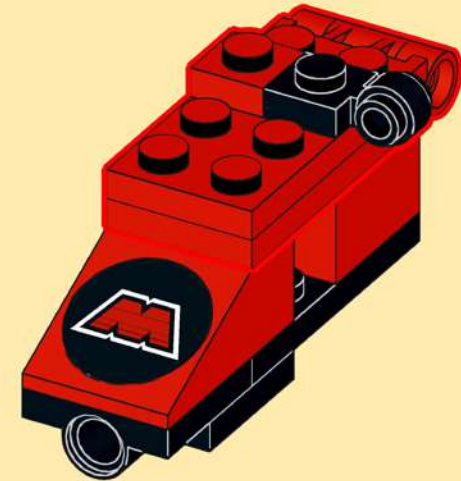
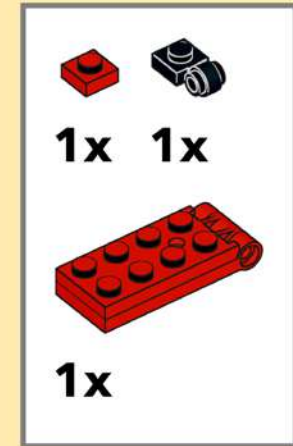

39

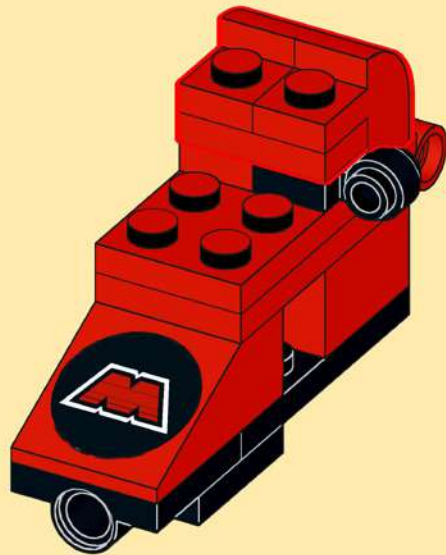
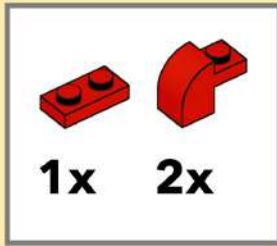

40

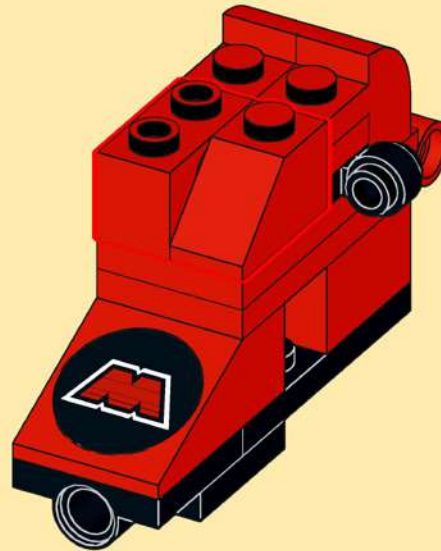
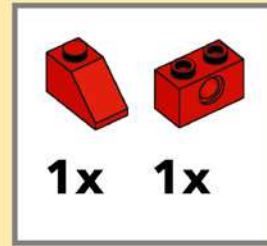

41

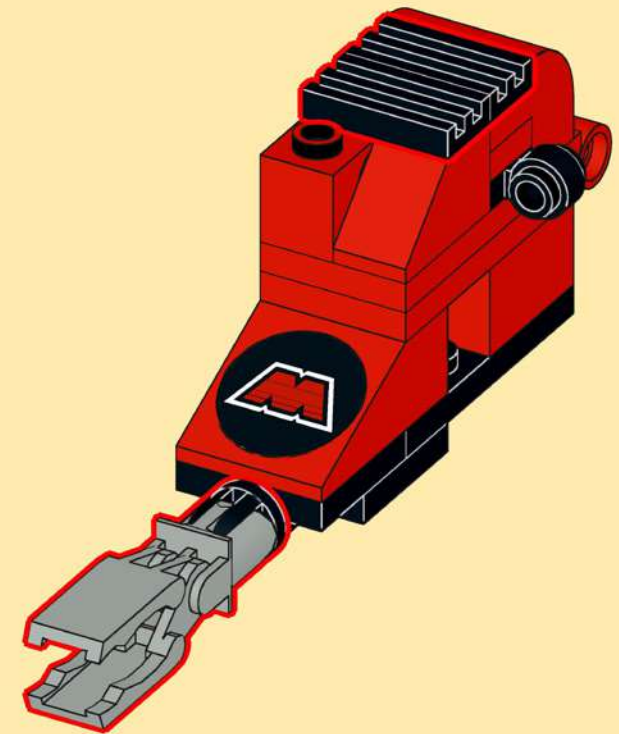
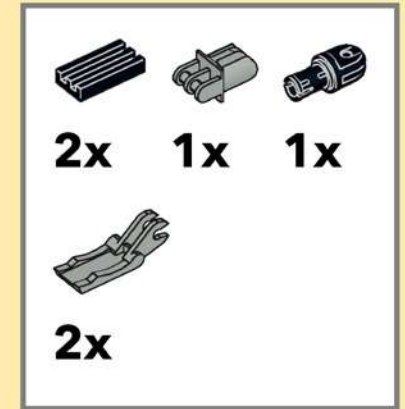

42

Construction tip

As depicted in the original image, the arms only fit with the grabbing hands tucked in. At this point you'll definitely notice why this prototype was never put into production as the arms dangle a bit loose.

Using a small bit of masking tape on the technic pin before mounting can create the right amount of friction to keep the arms in place.

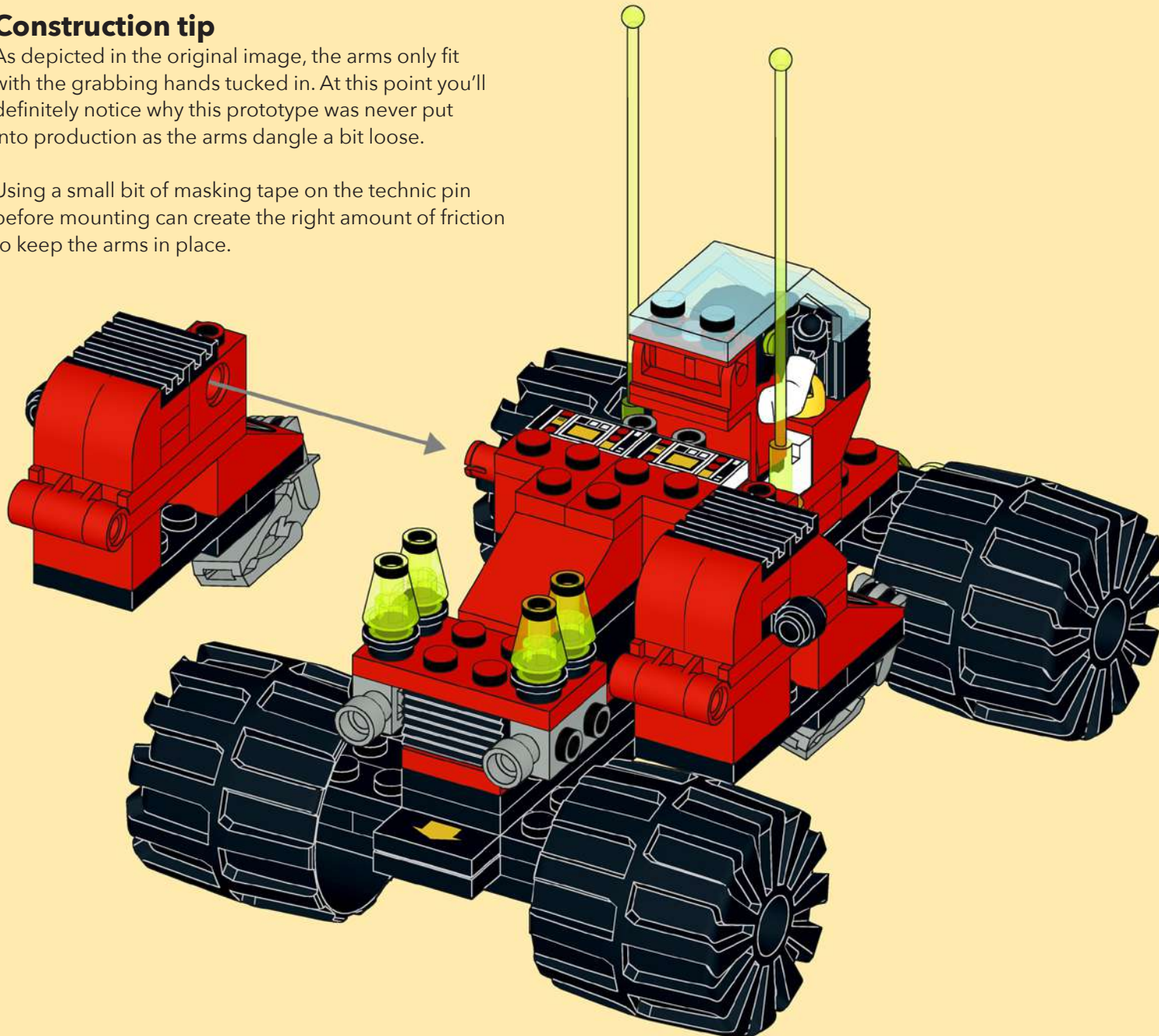

Transform!

All done! The rover on the left can transform into the mecha shown right, by simultaneously pushing the front lights and black arrow decorated tile at the rear end inward. Readjust the cabin and arms when raised.

